

Datasheet - Fibrocimento L - Madeira

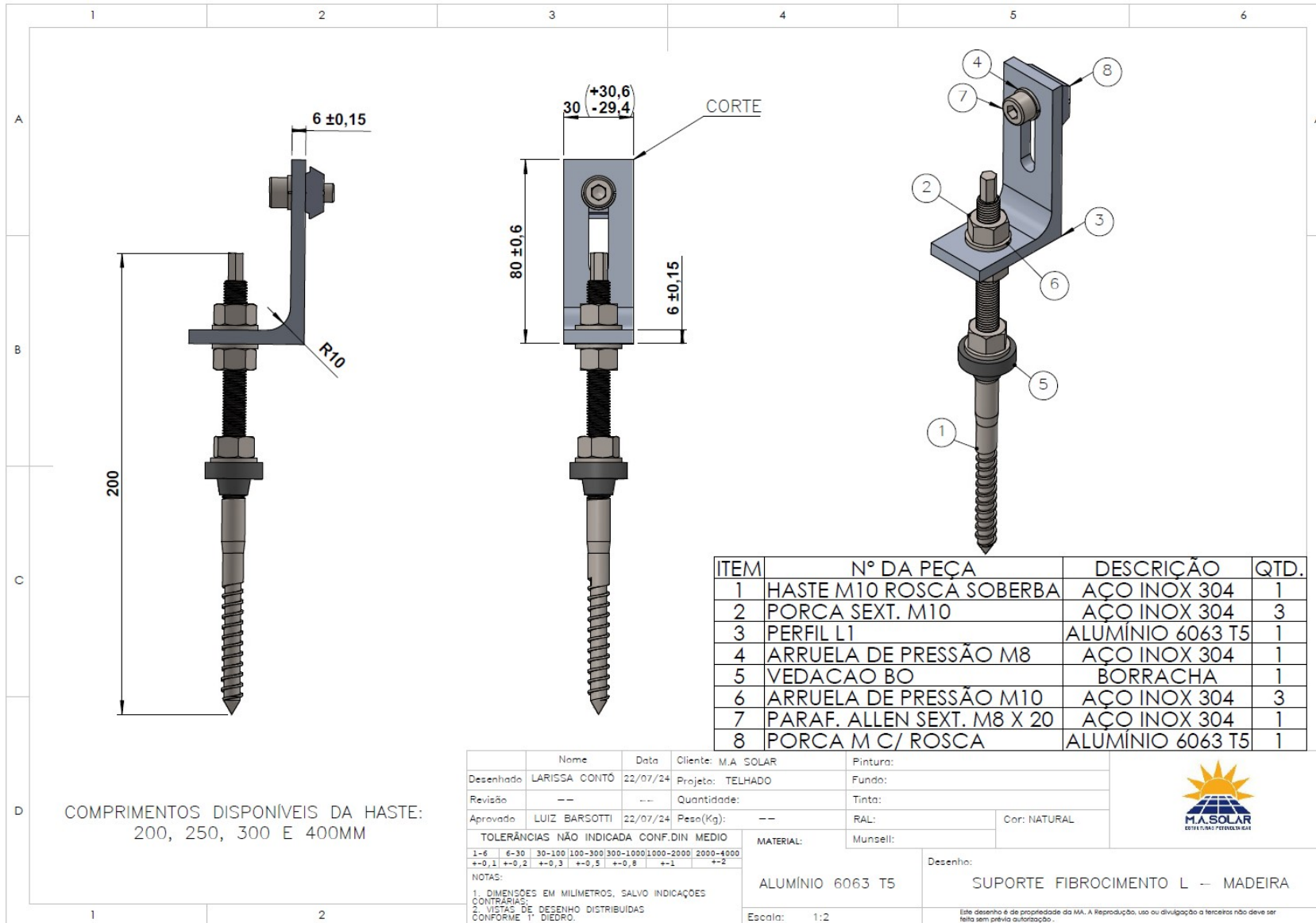

Luiz Barsotti
Engenheiro responsável

Luiz Gustavo
Diretor

Ricardo Yamazaki
Gerente de extrusão

 comercial@masolargroup.com.br

 www.masolargroup.com.br

 Rua Aureliano César do Nascimento, 445 e 475, Iporanga - Sorocaba/SP

 M.A Solar Group

 @m.a.solargroup

 15 3325 - 3418